

Vario Relax 3000[®]



TRAIN | REGIONAL TRANSPORT



crash-safe

resistant

universal



VARIO RELAX 3000®

The VARIO RELAX 3000 seat has been specially developed for daily use in commuter trains and regional trains. The seat consists of a self-supporting and robust aluminum structure and is highly crash-safe and fire-proof.



Vario Relax 3000R



Vario Relax 3000



The three-part upholstery is divided into the upper seat as a separate headrest, backrest and seat cushion.

A gap-free arrangement in the lower part of the backrest of multi-seat seats is achieved by pushing the seats together. This fulfills the requirement of a „pick pocket guards“.

All metal parts are powder coated; the RAL colors are up to a free customer's choice.

The seat and back cushions are fitted without intermediate gap in the lateral aluminum profiles, so that the pad protrudes up to the profile edge. The attachment of the upholstery is quickly interchangeable. The upholstery carriers are made of fire-resistant laminated wood. The respective upholstery fabric of the seat can be selected according to customer requirements.

Product features and benefits:

- **Modern design**
- **Crash-proofed to fulfill GM/RT 2100**
- **Fire proof due to metal structure**
- **High stability cause of innovative use of tools**
- **3-part upholstery (seat cushion, back, headrest)**
- **High modularity**
- **Durable and robust**
- **Design line of the back tapers upwards**
- **Closed grip, request for more grips**
- **Quick change system for upholstery via hook tape**
- **“Pickpocket” guard**

DIMENSIONS

exemplary

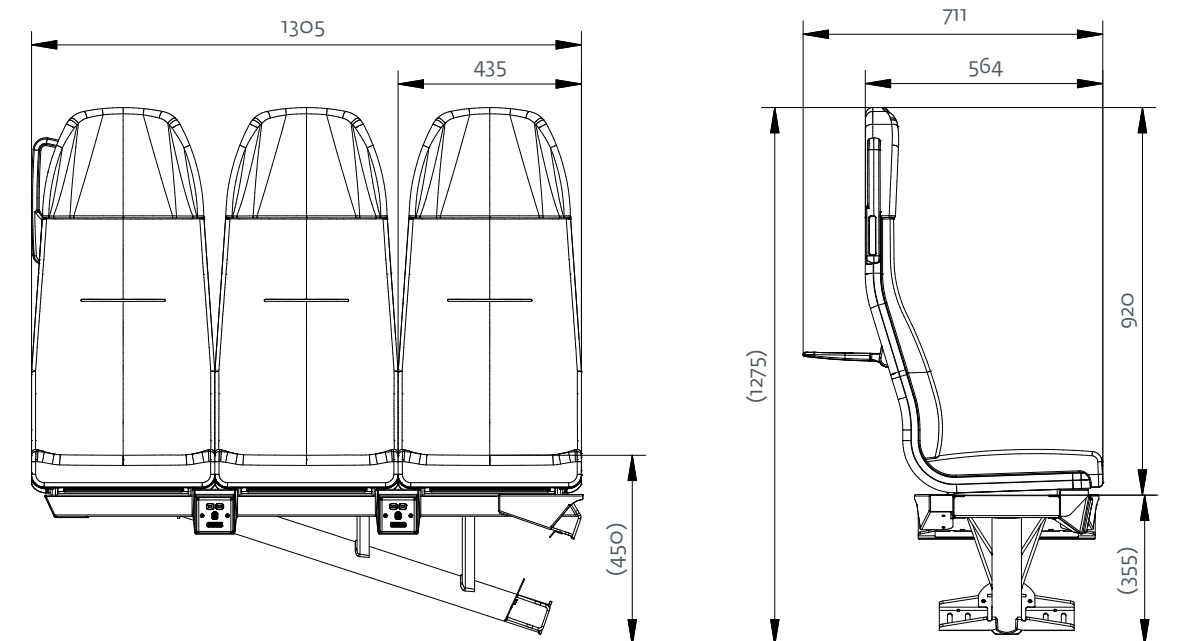

THREE SEAT COMBINATION



PRODUCT OVERVIEW

SEAT TYPES

Single seat	<input checked="" type="checkbox"/>
Double seat	<input checked="" type="checkbox"/>
Back to back seating	<input type="checkbox"/>
Three seat combination	<input type="checkbox"/>

DIMENSIONS

Single seat width	435 mm, 450 mm
-------------------	----------------

FEATURES

Full-padded	<input checked="" type="checkbox"/>
Reclining system	<input type="checkbox"/>

ACCESSORIES

Table wie cup mold and gap for smart device	<input checked="" type="checkbox"/>
Fixed armrest	<input type="checkbox"/>
Foldable armrest	<input type="checkbox"/>
Grasp handle closed	<input checked="" type="checkbox"/>
Cantilever fixation	<input checked="" type="checkbox"/>
Socket with USB	<input checked="" type="checkbox"/>

WEIGHT

Double seat (standard version)	ca. 42,2 kg
--------------------------------	-------------

Compliant with legal requirements:

UIC 566 | UIC 564 | EN 45545 HL2 | DIN 5510 |
GM/RT 2100 | BS 6853 cat 1b

- Standard
- Option





Franz Kiel GmbH

Nürnberger Straße 62
86720 Nördlingen
Germany

Tel. +49 (0) 90 81/21 03 - 0
Fax +49 (0) 90 81/21 03 - 151

info@kiel-sitze.de
www.kiel-sitze.de

DRIVEN BY **INNOVATION**

