

LEXXO® / LIGERO®



BUS | REGIONAL TRANSPORT



lightweight

diverse

versatile



LEXXO®/LIGERO®



The Seating systems LEXXO and LIGERO are especially designed for regional transportation. They set new standards in terms of comfort, design and modularity.

The Seating systems have a high level of versatility. The modular design concept allows the adaption to almost any installation requirement.

Due to the ergonomic styling and the very thin backrest the seat features a maximum leg room for passengers, nevertheless the seat provides a high level of comfort.

The modular design concept allows replacement of all major parts and a quick-release of seat and back cushions.



DIMENSIONS

LIGERO 1000 HF

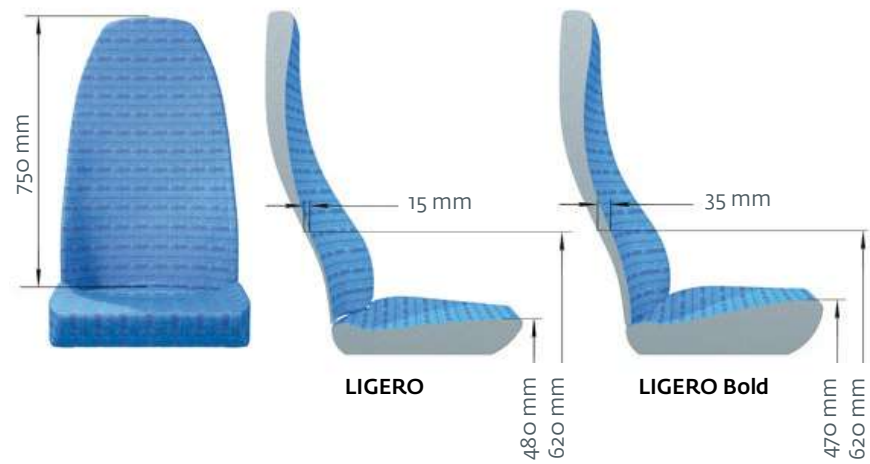

LIGERO 3000/700 HF

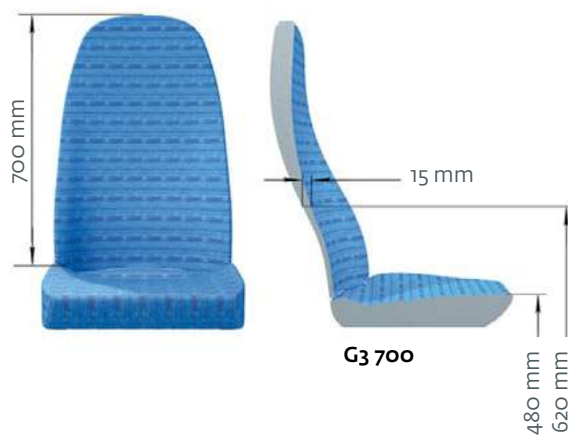

LIGERO 3000/750 HF



LIGERO 3000 R

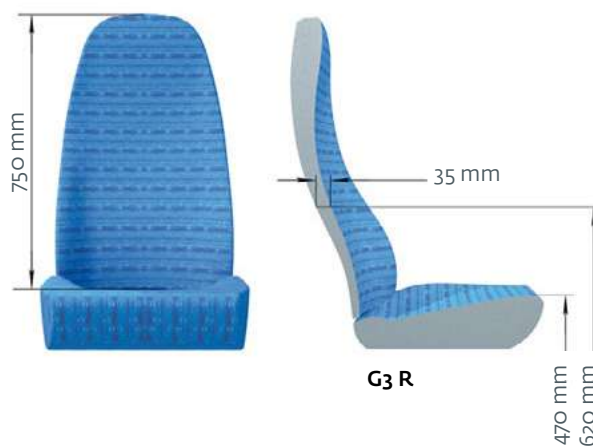

LEXXO

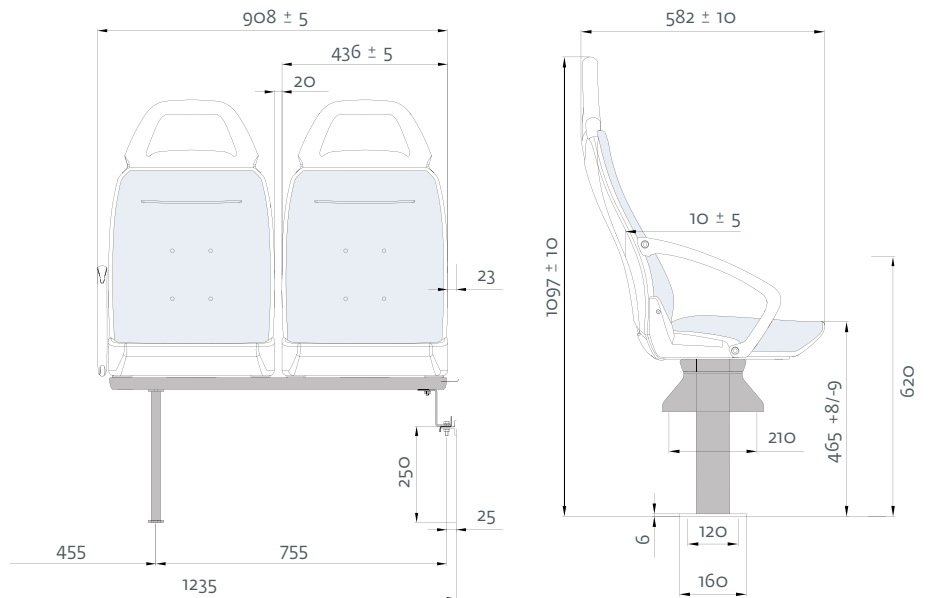

LEXXO CT

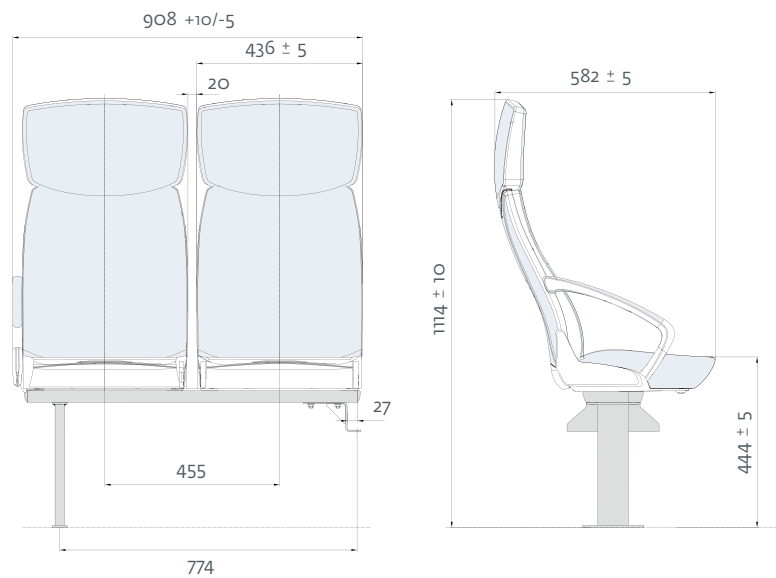

LIGERO 1000 HF

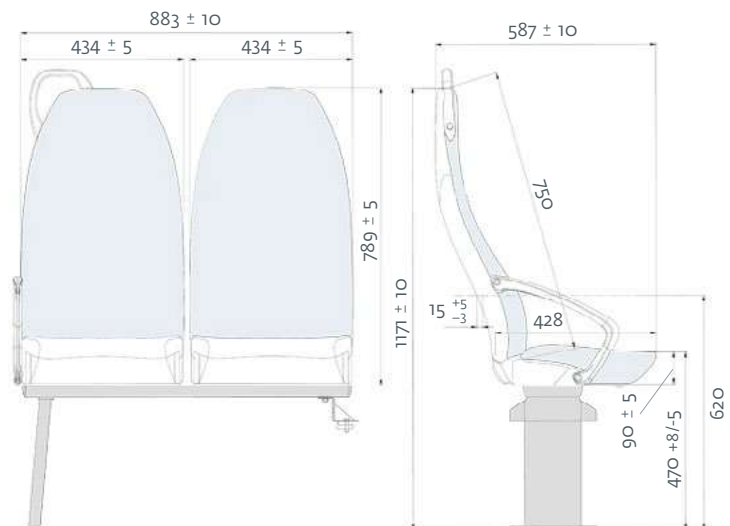

LIGERO 3000/700 HF

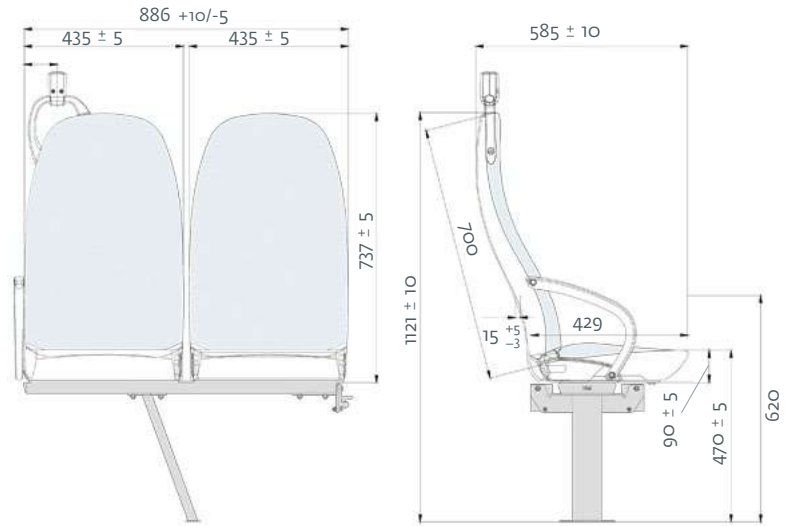

LIGERO 3000/750 HF

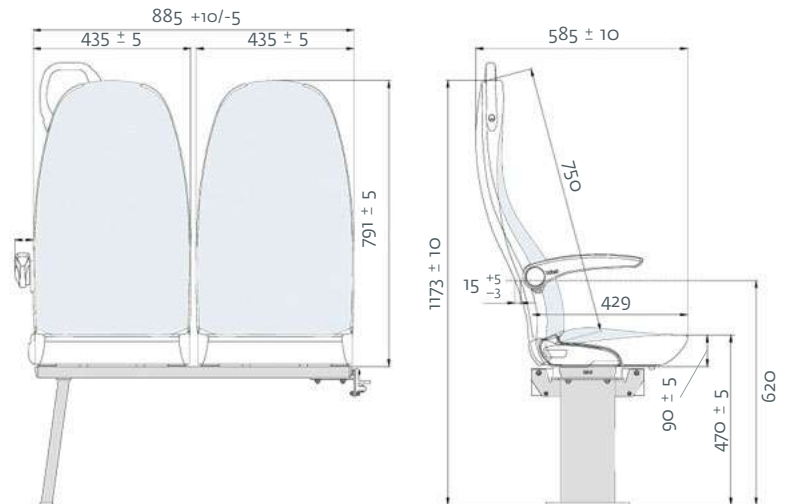

LIGERO 3000 R

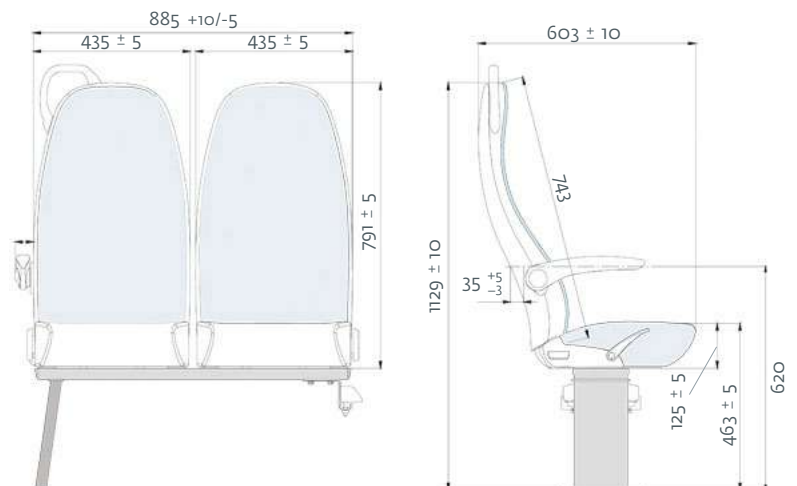

LEXXO



Robust seat for application in local and regional transport

Utilization of high quality materials

LEXXO CT



The seat features an ultramodern design in combination with a high level of comfort

Application in local and regional transport

LIGERO 1000 HF



Light weight and modular passenger seat for application in buses for regional transport

LIGERO 3000/700 HF



LIGERO 3000/750 HF



Innovative seating solution for regional buses and mini vans

Lightweight design

Ergonomic shaped backrest and seat pads

Wide variety of optional extras

LIGERO 3000 R



EQUIPMENT

LEXXO / LEXXO CT

EQUIPMENT OPTIONS



Grab handle Lexxo



Head rest Lexxo CT



Grab handle Lexxo CT



2-point bow-type handle



2-point bow-type handle version high



Armrest foldable



LIGERO 1000 HF

EQUIPMENT OPTIONS



Corner handle



Aisle armrest



Fold-up armrest



Cover with Customizing Option



Backrest with Customizing Option



Handle on back



Magazine net

BACK REST OPTIONS



Fabric (Mirex)



Fabric (Mirex)



Fabric on customer request



2/3 Backrest cover



Backrest cover two-colored

EQUIPMENT

LIGERO 3000

EQUIPMENT OPTIONS



Corner handle



Aisle armrest



Fold-up armrest



Side cover with Customising Option



Standard side cover for belt buckle with Customising Option

BACK REST OPTIONS



Fabric (Mirex)



Fabric on customer request



Backrest cover



Handle on the back



Magazine net

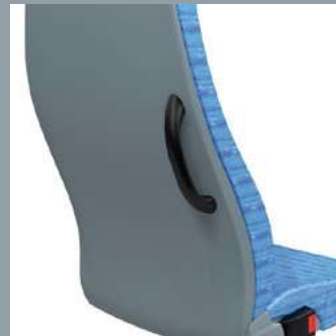

School bus grip
(handle for children/
persons with handicap)



Seat cushions height = 90 mm



Seat cushions height = 125 mm

PRODUCT OVERVIEW

SEAT TYPES	LEX XO	LEX XO CT	LIGERO 1000 HF/BOLD	LIGERO 3000/700 HF	LIGERO 3000/750 HF	LIGERO 3000 R
Single seat	■	■	■	■	■	■
Double seat	■	■	■	■	■	■
Tip-up seat	□	□	□	□	□	–
Back to back seating	□	□	□	□	□	–
Longitudinal seat	□	□	□	□	□	–

DIMENSIONS	LEX XO	LEX XO CT	LIGERO 1000 HF/BOLD	LIGERO 3000/700 HF	LIGERO 3000/750 HF	LIGERO 3000 R
Single seat width	430 mm	430 mm	434 mm	435 mm	435 mm	435 mm
Total seat width	908 mm	908 mm	883 mm	886 mm	885 mm	885 mm

FEATURES	LEX XO	LEX XO CT	LIGERO 1000 HF/BOLD	LIGERO 3000/700 HF	LIGERO 3000/750 HF	LIGERO 3000 R
Backrest fixed	■	■	■	■	■	–
Backrest adjustable	–	–	–	–	–	■

RESTRAINT SYSTEM	LEX XO	LEX XO CT	LIGERO 1000 HF/BOLD	LIGERO 3000/700 HF	LIGERO 3000/750 HF	LIGERO 3000 R
2-point seat belt	□	□	□	□	□	□
3-point seat belt	–	–	□	□	□	□
Belt hook for children / juveniles	–	–	□	□	□	□

- Standard
- Option
- not available



ACCESSORIES	LEXXO	LEXXO CT	LIGERO 1000 HF/BOLD	LIGERO 3000/700 HF	LIGERO 3000/750 HF	LIGERO 3000 R
Bow-type handle	<input type="checkbox"/>	<input type="checkbox"/>	<input type="checkbox"/>	<input type="checkbox"/>	<input type="checkbox"/>	–
Armrest foldable	<input type="checkbox"/>	<input type="checkbox"/>	<input type="checkbox"/>	<input type="checkbox"/>	<input type="checkbox"/>	<input type="checkbox"/>
Armrest light	<input type="checkbox"/>	<input type="checkbox"/>	<input type="checkbox"/>	<input type="checkbox"/>	<input type="checkbox"/>	<input type="checkbox"/>
Grasp handle	<input type="checkbox"/>	<input type="checkbox"/>	<input type="checkbox"/>	<input type="checkbox"/>	<input type="checkbox"/>	<input type="checkbox"/>
Handle on back (horizontal)	–	–	<input type="checkbox"/>	<input type="checkbox"/>	<input type="checkbox"/>	<input type="checkbox"/>
Footrest adjustable	–	–	<input type="checkbox"/>	<input type="checkbox"/>	<input type="checkbox"/>	<input type="checkbox"/>
Magazine net	–	–	<input type="checkbox"/>	<input type="checkbox"/>	<input type="checkbox"/>	<input type="checkbox"/>
School handle	–	–	–	<input type="checkbox"/>	<input type="checkbox"/>	<input type="checkbox"/>
Stanchion fitting	<input type="checkbox"/>	–	<input type="checkbox"/>	<input type="checkbox"/>	<input type="checkbox"/>	–
Cantilever fixation	<input type="checkbox"/>	<input type="checkbox"/>	<input type="checkbox"/>	<input type="checkbox"/>	<input type="checkbox"/>	–
Full backrest cover	<input checked="" type="checkbox"/>	<input checked="" type="checkbox"/>	<input type="checkbox"/>	<input type="checkbox"/>	<input type="checkbox"/>	<input type="checkbox"/>
2/3 backrest cover	<input type="checkbox"/>	<input type="checkbox"/>	<input type="checkbox"/>	–	<input type="checkbox"/>	<input type="checkbox"/>
Seat cushions standard (H = 90 mm)	<input checked="" type="checkbox"/>	<input checked="" type="checkbox"/>	<input checked="" type="checkbox"/>	<input checked="" type="checkbox"/>	<input type="checkbox"/>	<input type="checkbox"/>
Seat cushions high (H = 125 mm)	–	–	<input type="checkbox"/>	<input type="checkbox"/>	<input type="checkbox"/>	<input checked="" type="checkbox"/>

WEIGHT	LEXXO	LEXXO CT	LIGERO 1000 HF/BOLD	LIGERO 3000/700 HF	LIGERO 3000/750 HF	LIGERO 3000 R
Double seat (standard) without belts	ca. 16,5 kg	ca. 17,0 kg	ca. 17,0 kg	ca. 17,5 kg		
Double seat (standard) with 2-p. belts					ca. 21,0 kg	ca. 25,6 kg
Double seat (standard) with 3-p. belts					ca. 25,2 kg	ca. 28,5 kg

Compliant with legal requirements:
ECE-R 80 | ECE-R 118 | RL95/28/EG

- Standard
- Option
- not available





Franz Kiel GmbH

Nürnberger Straße 62
86720 Nördlingen
Germany

Tel. +49 (0) 90 81/21 03 - 0
Fax +49 (0) 90 81/21 03 - 151

info@kiel-sitze.de
www.kiel-sitze.de

DRIVEN BY **INNOVATION**

